

V1.0

Initial version.

V1.0B

- 1.Add R15 & R16 to 54331 en pin, The input must be greater than 15V, TPS54331 can start to work, and 12V can output.
- 2.Change R19 to 75K and C36 to 1000pF to get a better 12V output.
- 3.Fix some silk mistake
- 4.Change CD4504 VCC to 12V
- 5.Mirror EXP3 for Raspberry Pi.
- 6.Add R20 for F407 replace.
- 7.Add LED for the 3 fans

V1.1

- 1.Add 5pin connector for BL-Touch
- 2.Change EXP1 & EXP2 mark
- 3.Add +/- mark

V2.0

- 1.Add 48V stepstick support x3
- 2.Add TVS and Bleeding resistance to every stepstick socket
- 3.Change 12V/5A to SY8205
- 4.Change the Raspberry Pi 5V and system 5V to separate DC-DC circuits (3A per channel)
- 5.Add separate 3.3V to stepsticks
- 6.Change PCB to 6 layers
- 7. Optimize some wiring.
- 8.Change the series diode of the driver circuit to a 15A fuse (1808)

V2.1

- 1.Change 48V stepstick support to 2
- 2.Change 12V/5A to 12V/3A
- 3.Change the Raspberry Pi 5V (3A to 5A) and system 5V(5A to 3A)
- 4.Add RESET 1x2 Pin header

V2.2

- 1.Add two thermistor sockets, a total of 6.
- 2.Change FAN0 to PA13, FAN1 to PA14.
- 3.Add pin definition silkscreen on the bottom.

Title Version.SchDoc			 www.fysetc.com
Size: A4	Number:	Revision:	
Date: 2021-08-26	Author: *	Sheet of	

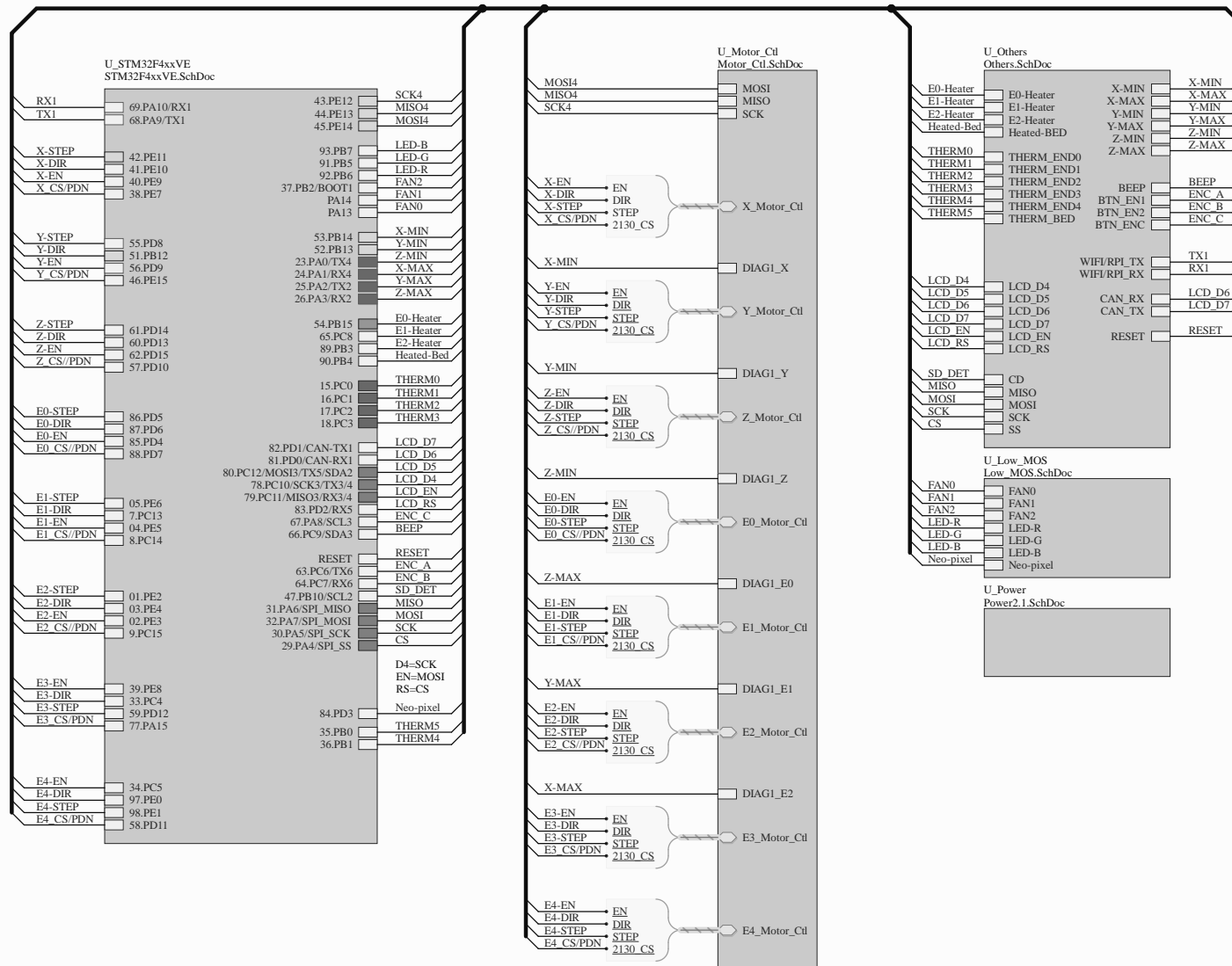

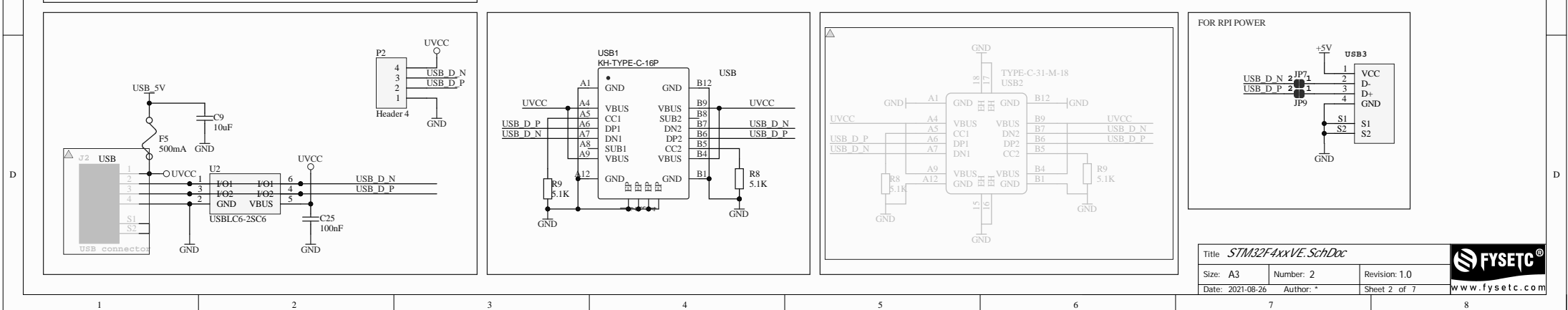
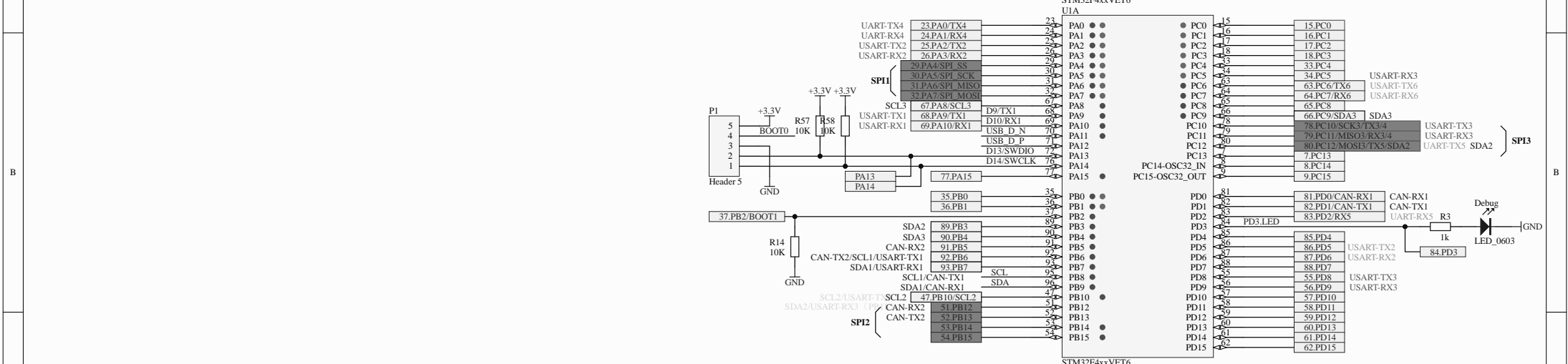
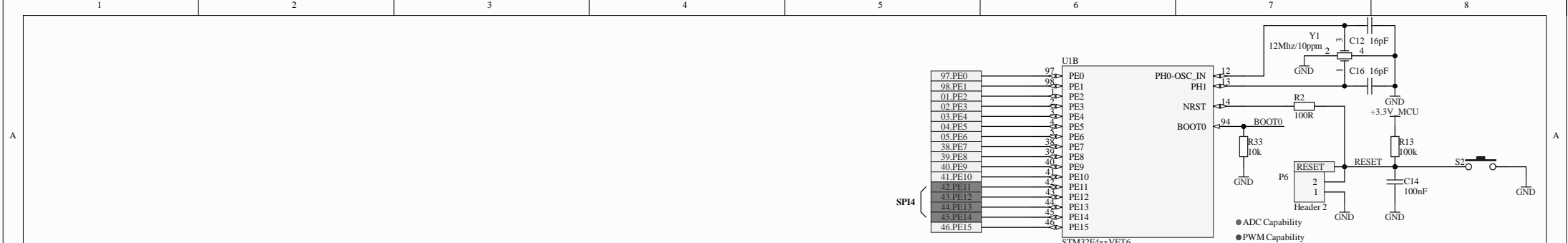

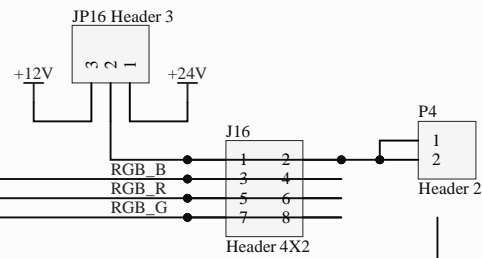
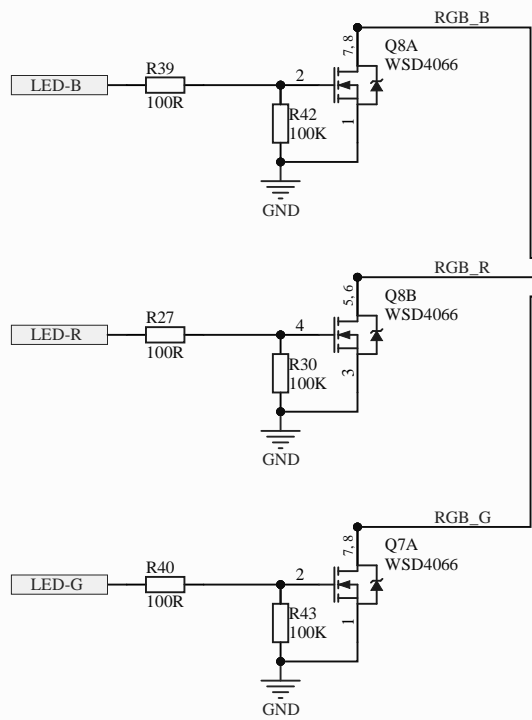
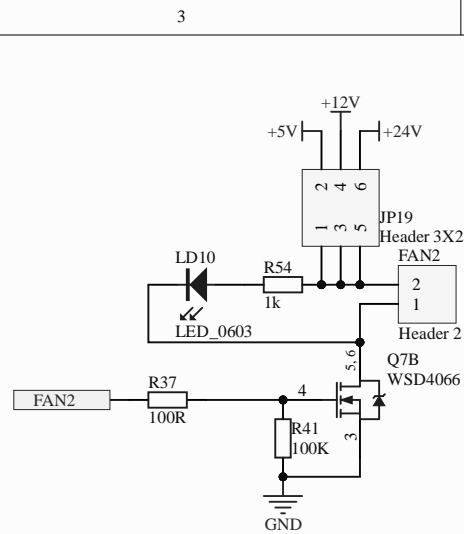
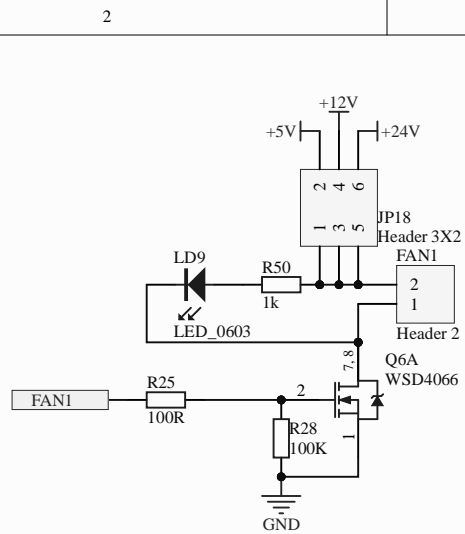
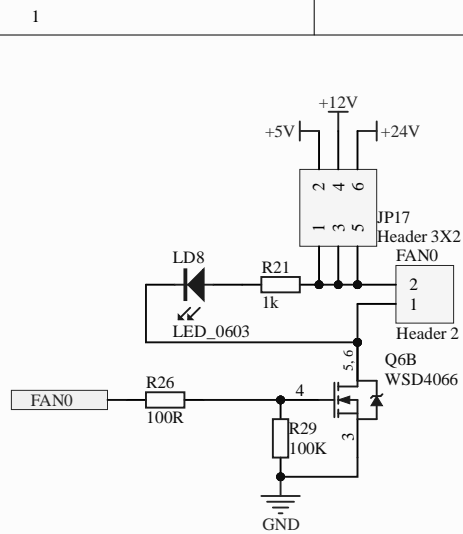

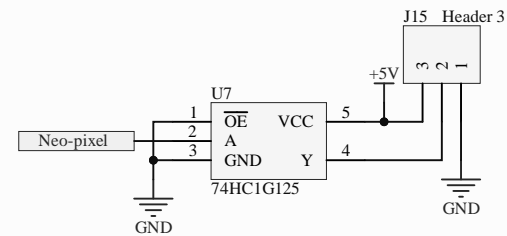

with this pin, three RGB channels can be converted to ordinary 2pin PWM output, Such as USED FOR FAN.

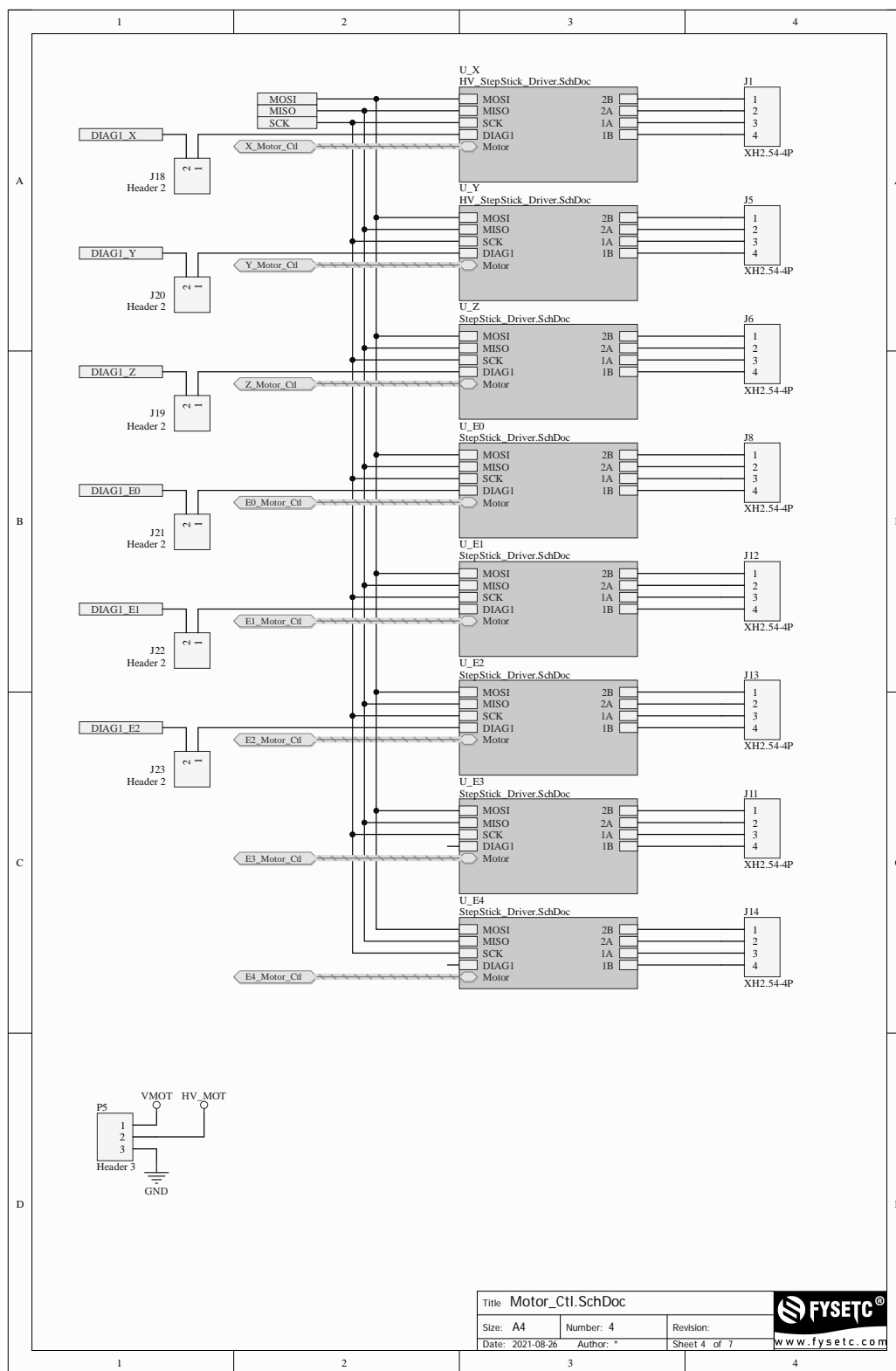

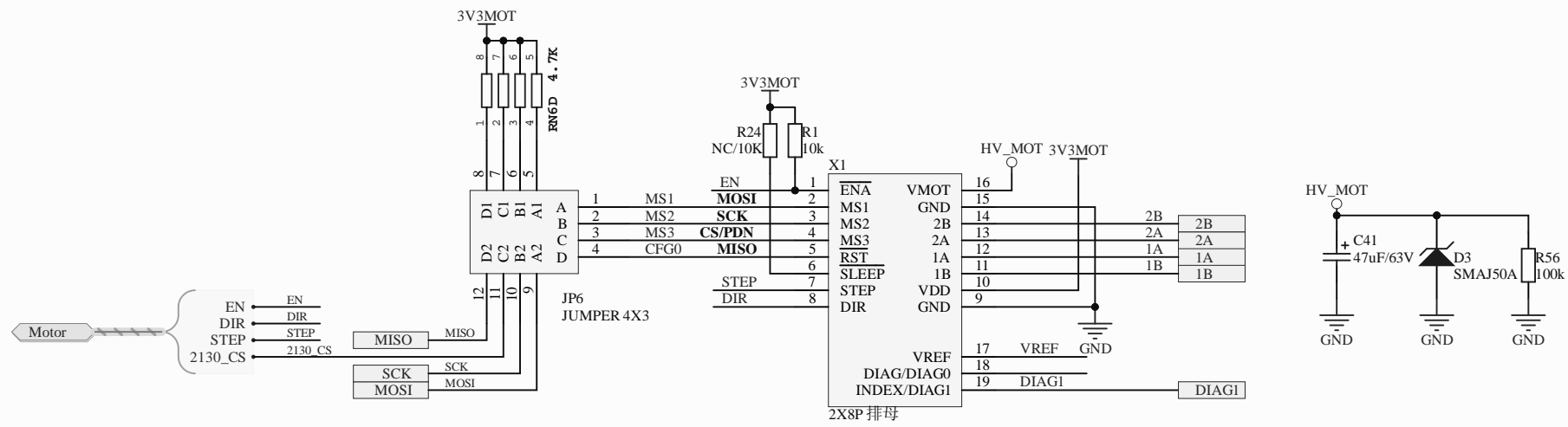

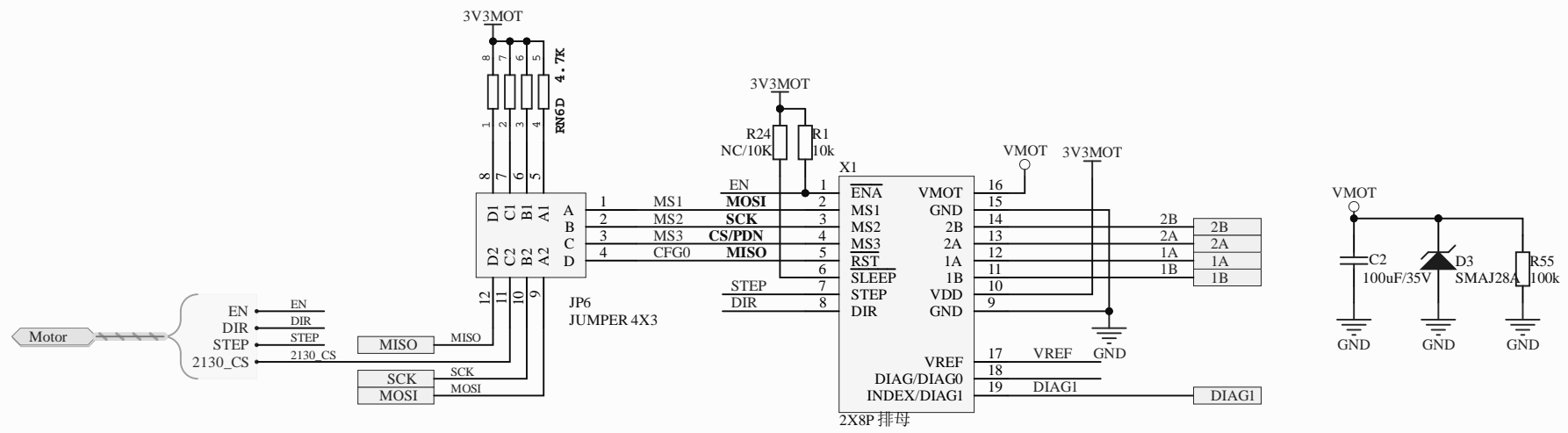



Title StepStick_Driver.SchDoc			 www.fysetc.com
Size: A4	Number: 5	Revision: 1.0	
Date: 2021-08-26	Author: *	Sheet 5 of 7	

A

B

C

D

A

B

C

D

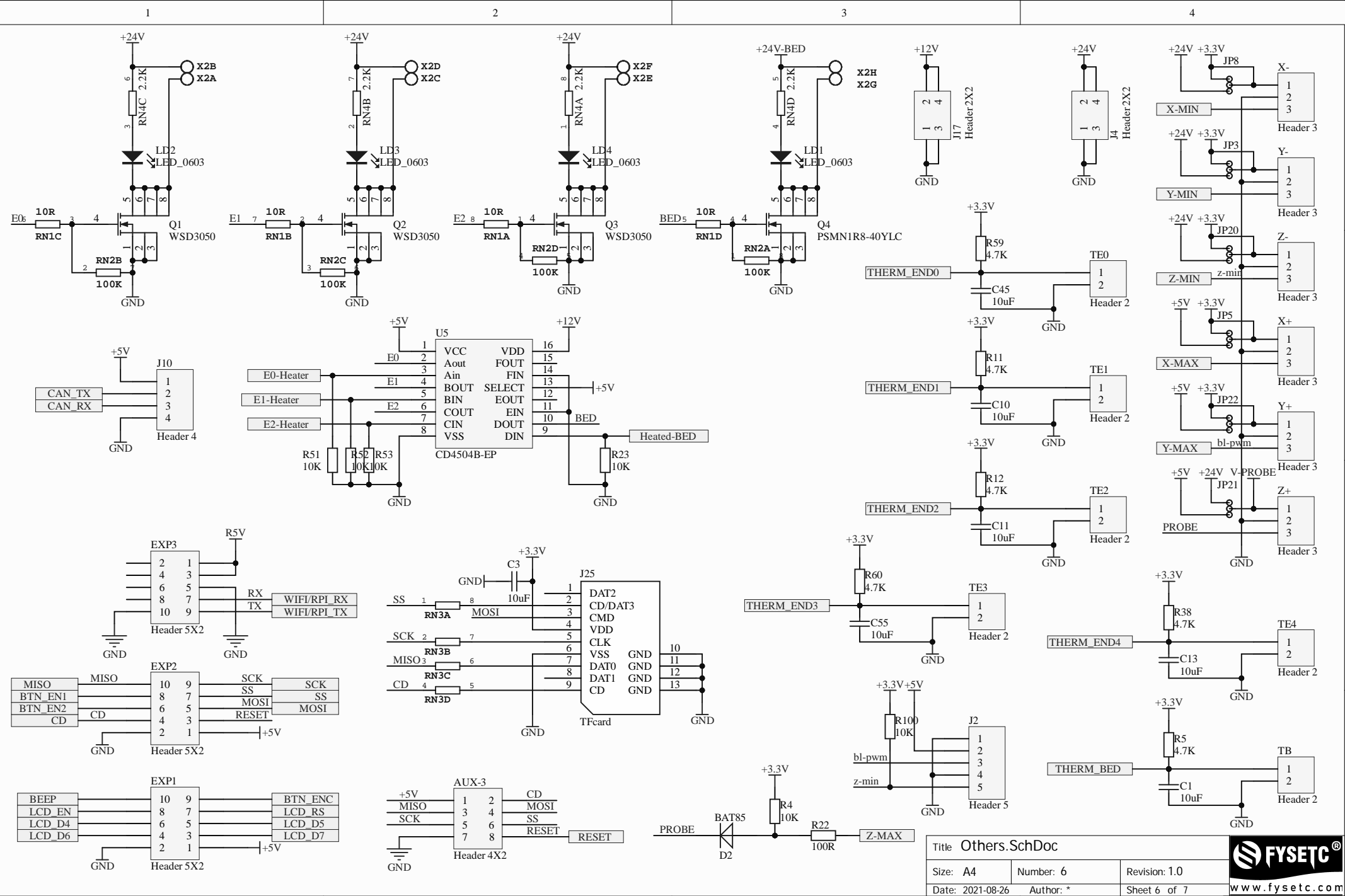

Title Others.SchDoc			 www.fysetc.com
Size: A4	Number: 6	Revision: 1.0	
Date: 2021-08-26	Author: *	Sheet 6 of 7	

